



**ALP<sup>®</sup> 900**

**Currie Medical DVT Prevention System**

**User Manual**



## Table of Contents

I. Product Info, Illustrations & Key	3
II. Intended Use, Scope & Description	5
III. Product Technical Specs & Performance	6
IV. Contraindications for Use	10
V. Cautions, Warnings & Indicators	11
VI. Instructions for Installation & Operation	13
VII. Cleaning, Service, Maintenance, Storage & Transportation	25
VIII. Configuration, Serial Number, Country of Origin & Shelf Life	27
IX. Symbols Explanation	28
X. EMC Appendix	29

## I. Product Information, Illustrations & Key

**Product Name:** Currie Medical ALP<sup>®</sup> DVT Prevention System

**Pump Model No.:** ALP<sup>®</sup> 900

The Currie DVT prevention system consists of a main control unit (pump), a pair of air hoses, and a pair of compression garments/sleeves (of various sizes/purposes for use with the calf, thigh, foot, etc.).

**ALP<sup>®</sup> 900 Diagram**

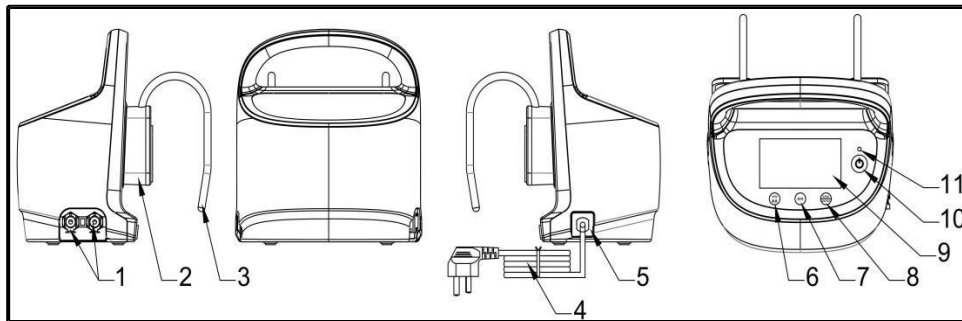

1. **Air Outlets:** Connects the air hoses.
2. **Cable Holding Slot:** Stores the power cord and air hoses.
3. **Bed Hook:** A rotary-type hook to suspend the device from the hospital bed.
4. **Power Cord:** Connects the system to the AC power supply.
5. **Buckle:** Secures the power cord to prevent it from being removed.
6. **Time Reset Button:** Resets the therapy duration time to 0, enters the time setting page, and increases the countdown duration.
7. **Pause Button:** Pauses and resumes therapy, and confirms the time mode setting.
8. **Foot Mode/Alarm Pause Button:** Switches foot mode, mutes alarms, enters the time setting page, and decreases the timed therapy duration.
9. **LCD Screen:** Displays the operating status of the system, sleeve type, pressure, battery level, alarm info, therapy time, countdown and more.
10. **On/Off Button:** Powers the system on and off.
11. **Power Source LED:** Illuminates green when the device is using AC power and blue when using battery power.

## ALP® 900 LCD Display Diagram

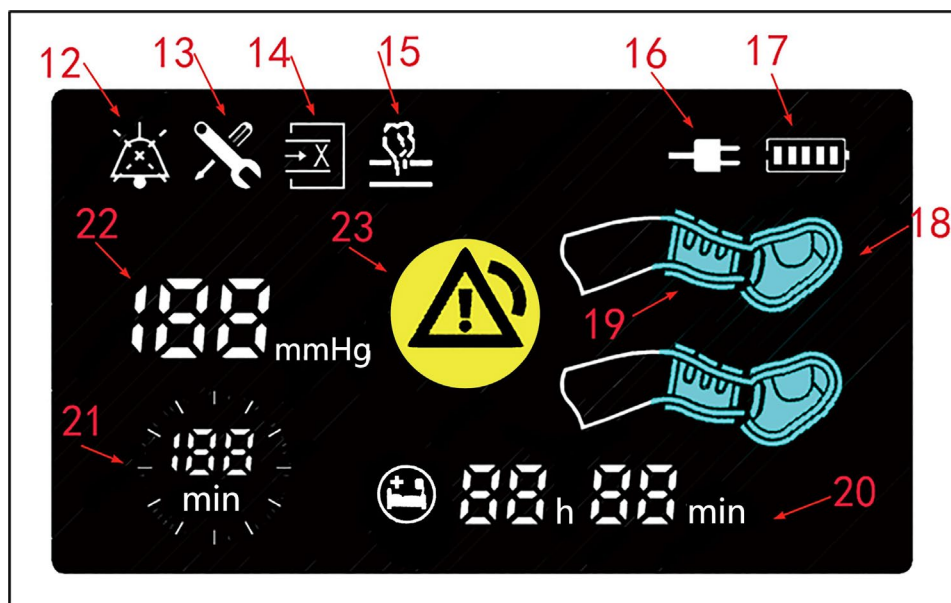

12. **Alarm Mute icon:** Displays after alarm sound is paused

13. **Fault indicator:** System fault indication

14. **Fault indicator:** High pressure indication

15. **Fault indicator:** Low pressure indication

16. **AC power source indicator:** Displays when unit is plugged into an AC power source

17. **Battery level:** Battery icon is displayed according to current battery level

18. **Garment/Sleeve type icon:** Indicates foot sleeve is connected

19. **Garment/Sleeve type icon:** Indicates calf or thigh sleeve is connected

20. **Therapy duration timer:** Displays current cumulative duration of therapy time in hours and minutes

21. **Therapy countdown indicator:** If countdown option is selected, displays treatment time remaining

22. **Garment/Sleeve pressure indicator:** Displays when 40mmHg is reached for calf and thigh sleeves (or when 120mmHg is reached for foot sleeves).

23. **Alarm icon:** Displays when unit is alarming

## II. Intended Use, Scope and Description

The Currie ALP® DVT Prevention System is intended for use in adult patients in hospital settings to increase venous blood flow in order to help prevent deep vein thrombosis (DVT).

The ALP® 900 is an alternating, intermittent pneumatic pump designed to aid in the prevention of DVT, a potentially life-threatening condition that can lead to pulmonary embolism. This non-invasive mechanical prophylactic system helps reduce the incidence of DVT by essentially functioning as a secondary pump to assist in propelling venous blood for bedridden patients during and after surgeries.

The ALP® 900 device is reusable, designed to be used for multiple patients throughout its lifecycle, provided that thorough disinfection and cleaning are completed between uses.

In addition to the pump, the DVT prevention system includes soft, pliable compression garments/sleeves (sold separately) for use with the foot, calf, or thigh. For the purpose of these instructions, the terms “garment” and “sleeve” refer to the same device and are used interchangeably in this document. The ALP® 900 delivers compression in pre-set timing cycles (12 seconds of inflation and maintenance followed by 48 seconds of deflation) with a recommended pressure setting of 40mmHg for the leg and 120mmHg for the foot. The pressure in the garments is transferred to the extremity, augmenting venous blood flow when the leg is compressed and reducing stasis. This process also stimulates fibrinolysis, thereby reducing the risk of early clot formation.

The ALP® 900 pump produces automatically timed cycles of compressed air, which forces blood out of the deep veins to help prevent slowed or stopped blood flow. Bursts of air are delivered to the specially designed garments wrapped around the extremities, helping to move blood out of the deep veins and reduce the risk of developing DVT. The garments are lined with moisture-wicking tricot fabric to help reduce heat and perspiration.

### III: Product Technical Specs & Performance

#### 3.1 Standard Operating Settings & Performance

##### 3.1.1 Therapy Modes

Therapy Mode	Leg Mode	Foot Mode
Chamber Number	Single	Single
Compression Sequence	Uniform pressure, cyclic inflation and deflation, 2 sleeves one by one	Uniform pressure, cyclic inflation and deflation, 2 sleeves one by one
Pressure	40 <sup>+10</sup> mmHg -5	120 <sup>+10</sup> mmHg -5
Inflation Time	12 seconds ±1 second	12 seconds ±1 second
Deflation Time	48 seconds ±2 seconds	48 seconds ±2 seconds
Cycle Time	60 seconds ±3 seconds	60 seconds ±3 seconds

##### 3.1.2 Output Pressure Duration

- The duration of output pressure above 3 kPa (22.5 mmHg) does not exceed 10 minutes.

##### 3.1.3 Overvoltage Protection

- The pressure delivered to the limb exceeds 120% of the maximum therapy pressure for no more than 1 second under normal and single failure conditions.

*Note: Under a single fault condition, such as if the solenoid valve is unplugged or the pressure sensor's connecting tubing is disconnected, the equipment will stop working.*

##### 3.1.4 Function Switch

- The device features a pause button that can stop the treatment procedure at any time, independent of the power switch. The device automatically releases the pressure in the sleeves after the treatment procedure is discontinued.

### 3.1.5 Pressure Relief Measures

- In emergency situations, pressing the pause button will automatically release the pressure in the sleeves, reducing the pressure in the chamber to less than 3 kPa (22.5 mmHg) within 10 seconds. If the AC power supply or internal power supply is interrupted, the device will automatically release the pressure inside the sleeve.



### 3.1.6 Fault Alarms

- Low pressure alarm, high pressure alarm, system failure alarm, and low battery power alarm are all considered low priority alarms.
  - Low Pressure Alarm: During normal operation, if the treatment pressure is too low, the equipment will sound an audible alarm and display a visual warning on the screen.
  - High Pressure Alarm: During normal operation, if the treatment pressure is too high, the equipment will sound an audible alarm and display a visual warning on the screen. The device stops pressure output and releases pressure from the sleeves.
  - System Failure Alarm: During normal operation, if there is a system failure, the device will sound an audible alert and display a visual warning on the screen. The device stops pressure output and releases pressure from the sleeves.
  - Low Battery Power Alarm: During normal operation, if the battery power is too low, the device will sound an audible alarm and display a visual warning on the screen.
  - Alarm Pause: After the device triggers an alarm sound, pressing the "Alarm Pause/Foot Mode" button will pause the alarm sound (the screen will display the "🔕" icon). The audible alarm will resume after 10 minutes if the fault is not addressed. Pressing the "Alarm Pause/Foot Mode" button again will resume the alarm sound.

### 3.1.7 Visibility of Alarm Signals

- The visual alarm signal can be clearly detected from up to one meter from the operator's position.

### 3.1.8 Verification of Alarm System Effectiveness

- The user should verify the effectiveness of the alarm system once every 12 months.
  - Low Pressure Alarm: Connect the control unit, air hoses, and calf sleeves as specified in Section 6.3 of the Instructions for Installation and Operation. Turn on the equipment. After initialization, remove the calf sleeve from the air hose. The equipment should sound an alarm, and the low-pressure icon "" and alarm icon will display on the screen, indicating that the alarm system is effective.
  - High Pressure Alarm: Connect the control unit, air hoses, and calf sleeves as specified in Section 6.3 of the Instructions for Installation and Operation. Turn on the equipment. After initialization, remove the air hoses from the control unit. The equipment should sound an alarm, and the high-pressure icon "" and alarm icon will display on the screen, indicating that the alarm system is effective.
  - System Failure Alarm: Connect the control unit, air hoses, and calf sleeves as specified in Section 6.3 of the Instructions for Installation and Operation. Turn on the equipment. After initialization, unscrew the screw on the rear enclosure with a cross screwdriver, open the rear housing, and disconnect the solenoid valve. The equipment should sound an alarm, and the system failure icon "" and alarm icon will display on the screen, indicating that the alarm system is effective.
  - Low Battery Power Alarm: Connect the control unit, air hoses, and calf sleeves as specified in Section 6.3 of the Instructions for Installation and Operation. Turn on the equipment without connecting it to the AC power supply. When the battery is low, the alarm will sound, and the alarm icon will display on the screen, indicating that the alarm system is effective.

### 3.1.9 Operating Noise

- The noise level during normal operation does not exceed 60dB(A).

### 3.1.10 Fatigue Performance



- After applying the maximum nominal treatment pressure to the pressurized chamber and the connecting pipe 30,000 times, the chamber and pipe should show no significant deformation, loosening, cracking, or damage. For reusable sleeves and tube sets intended for a single patient, the number of tests is reduced to 5,000.

### 3.2 Product Technical Specifications and Safety Features

Item:	ALP® 900
Size:	218mm × 228mm × 158mm, tolerance ±5mm
Weight:	2.48 kg
Input Rating:	AC100-240V, 50/60Hz, 1A
Rated Voltage:	DC14.4V
Fuse Rating:	1A or T1A, 250V
Classification:	Class I, BF type 
Device Class:	Class II
Ingress Protection:	IPX0 (common type)
Operation Mode:	Continuous

*Note: The product should not be used in the presence of flammable anesthetic gasses mixed with air or with oxygen or nitrous oxide. The product does not have defibrillation discharge effect protection, signal input parts, or signal output parts. It is not designed to be permanently installed. Its electromagnetic compatibility is classified under GB 4824 as Group 1 Class A.*

### 3.3 Technical Specifications for Rechargeable Lithium Battery

- Battery Pack: 4 x series lithium-ion battery
- Battery Pack Capacity: Nominal 2900mAh, minimum 2750mAh

### 3.4 Software

- Software Version: V1.0.0.1

- Software Release Version: V1.0

### **3.5 Standard Conformance**

- IEC 60601-1: 2005 + AMD1:2012 + AMD2:2020 - Medical electrical systems part 1: General safety requirements.
- IEC 60601-1-2: 2014 + AMD1:2020 - Medical electrical systems part 1-2: General safety and electromagnetic compatibility requirements and tests.
- IEC 60601-1-8: 2006 + AMD1:2012 + AMD2:2020 - Medical electrical systems part 1-8: Common requirements for basic safety and performance of medical electrical systems and alarm systems in such systems.

## **IV. Contraindications for Use**

### **4.1 Not recommended with the following conditions**

- Severe congestive heart failure
- Severe arteriosclerosis or other ischemic vascular diseases
- Extreme deformity of the limbs
- Limbs with open wound(s)
- Known or suspected deep vein thrombosis (DVT)
- Any local condition where the garments would interfere with treatment, including:
  - Gangrene
  - Dermatitis
  - Untreated or infected wounds
  - Recent skin grafts

## **V. Cautions, Warnings, and Indicators**

### **5.1. Safety Warnings**

- It is the caregiver's responsibility to ensure the product is safe for use.
- Ensure that the power cable and tubing sets or air hoses are positioned to avoid tripping or other hazards and kept away from moving mechanical parts of the bed or other possible entrapment areas.
- Electrical systems may be dangerous if misused. There are no user-serviceable parts inside the device. Disassembly of this system must be completed by authorized technical personnel. No modification of this device is allowed.

- The power socket/plug must be accessible at all times. To disconnect the system from the AC power supply, remove the plug from the power socket.
- The system must be disconnected from the power supply before cleaning and inspection.
- Keep the system away from liquids and do not immerse it in water.
- Do not use the system in the presence of flammable liquids or gasses.
- The air hose and sleeve provided by Currie Medical are to be used with this system. The proper function of the system cannot be guaranteed if the incorrect air hose and sleeve are used.
- To avoid the risk of electric shock, the system must be connected to a protective grounding power supply grid.
- Unauthorized modification of the Medical Electrical (ME) systems can lead to hazards.
- Do not place the system where it is difficult to disconnect.

## 5.2 Precautions

- Proper use of the sleeve and proper connection to the control unit are crucial.
- The sleeve should be placed correctly and should not create any persistent pressure points on the patient's limb. Extra care should be taken when placing the sleeve on any deformed leg or foot, or on a leg with significant edema.
- Consider the lower limb placement in relation to the sleeves and catheters, especially in patients who are unconscious, unable to perceive, or have reduced ability to feel and/or move their legs.
- The patient's skin should be checked frequently during each shift.
- Correct clinical judgment needs to be used to determine if the patient's skin requires additional protection or if treatment should be stopped or other treatments used.
- If the patient experiences pain, allergy, numbness, swelling, redness, or other symptoms, the sleeve should be immediately removed, and a healthcare professional should be contacted.
- Use of the system should be in accordance with hospital policy and operated only by qualified medical personnel.
- The sleeve has two types: multiple-patient-use and single-patient-use. The single-patient-use sleeve cannot be used by multiple patients.
- The ALP<sup>®</sup> 900 system should be used with caution on patients with the following conditions:
  - Insensitive extremities
  - Diabetes
  - Impaired blood circulation
  - Impaired or fragile skin

## 5.3 Cautions

- The type of sleeve used for each patient must be specified by the physician.

- The above guidelines should not replace clinical experience or judgment.
- Treatment pressure, frequency, and duration should be determined at the doctor's clinical discretion.
- This system is not suitable for home healthcare; it is intended only for professional medical institutions.

#### 5.4 General Advice

- The patient should be checked more frequently if the patient has known circulation problems, skin diseases, or diabetes.
- Correct clinical judgment should be used to determine if the patient's skin requires additional protection or if treatment should be stopped or other treatments used.
- It is not recommended to use this DVT prevention system at the same time as compression stockings.

#### 5.5 Prevention of Deep Vein Thrombosis

- This system should be initiated preoperatively before anesthesia.
- The system should be used continuously for at least 72 hours after surgery, or until the patient is fully able to walk independently.
- If it is not possible to use the sleeve on the patient's limb during surgery, the sleeve can be used once the patient reaches the recovery ward.
- In patients who do not undergo surgery, this system should be used as soon as the risk of potential deep vein thrombosis is identified.
- The above recommendations are at the discretion of the clinician.

### VI. Instructions for Installation and Operation

Although the Currie system is designed for quick and easy setup/startup, we recommend first reading this instruction manual thoroughly to familiarize yourself with the entire DVT prevention system.

#### 6.1 ALP® 900 Pump Installation

Place the control unit on the floor or hook it onto the foot of the bed. Avoid hooking it on a slanted or curved surface. Do not hang it on a bed frame or bed rail with a thickness greater than 60mm, as this may damage the hook or casing. Do not turn on the unit yet.

#### 6.2 Sleeve Application

***Note: The type of sleeve used for each patient must be specified by the physician.***

## 6.2.2 Calf/Thigh Sleeve Application:

- a) **Sleeve Pairs:** Sleeves come in identical pairs and may be used on either leg. They are NOT specific to left or right legs/feet.
- b) **Dual Sleeves:** When using dual sleeves, identical sleeve types (same model) must be used on both legs. Sleeve combinations can be calf and calf, thigh and thigh, or foot and foot. DO NOT use any other combination.
- c) **Unpacking Sleeves:** Remove the sleeves from the package. Identical pairs may be used on either leg, with no left or right difference.
- d) **Positioning:** Position the sleeve at the appropriate ankle or knee mark.
- e) **Placement:** Place the side marked "THIS SECTION BEHIND CALF" on the patient's calf, with the tube end located at the ankle. For thigh sleeves, place the side marked "THIS SECTION BEHIND KNEE" on the back of the patient's knee (posterior knee fossa).
- f) **Securing the Sleeve:** Secure the hook fasteners of the sleeve from bottom to top, ensuring that all tabs are securely and tightly fastened to the sleeve.
- g) **Fit Check:** Use the "two-finger rule" to check the fit. Insert two fingers horizontally (with palm up and both fingers touching the patient's leg) between the sleeve and the patient. This should be done at both the top and bottom of the garment.
- h) **Repeat:** Apply the same procedures to the second identical model sleeve if needed.

*Note: If only one sleeve is to be used, leave the unused air outlet on the device free (no air hose attached). The ALP<sup>®</sup> 900 pump will automatically detect this during its initialization process.*

## 6.2.3 Foot Sleeve Application:

- a) **Sleeve Pairs:** Sleeves come in identical pairs and may be used on either leg.
- b) **Unpacking Sleeves:** Remove the sleeve(s) from the package. Identical pairs may be used on either leg, with no left or right difference.
- c) **Position:** The foot garment is printed with a foot graphic and marked "PLACE HERE LEFT OR RIGHT".
- d) **Securing the Sleeve:** Place the sole of the foot on the foot graphic of the garment. Use the right or left tab to cover the foot. Then wrap the strap behind the ankle as illustrated on the sleeve.
- e) **Fit Check:** Check that the sleeve is worn correctly by sliding a finger between the ball of the foot and the sleeve. If the finger inserts easily, the garment is too loose.
- f) **Repeat:** Apply the same procedures to the second identical model sleeve if needed.

*Note: If only one sleeve is to be used, leave the unused air outlet on the device free (no air hose attached). The ALP® 900 pump will automatically detect this during its initialization process.*

### 6.3. Connections

#### 6.3.1 Connect the Sleeve to the Air Hose:

- Each air hose has a white male connector at one end and a female connector at the other. The female end fits into the white male connector on the sleeve.
- A "click" sound indicates a proper connection. To disconnect, depress the metal side of the female connector and pull out the air tube of the sleeve.

#### 6.3.2 Connect the Control Unit to the Air Hoses:

- If not already attached, connect the white male connector of the air hose to the white female connector of the control unit. Repeat with the second air hose. These hoses are designed to stay permanently attached to the control unit. Do NOT detach these hoses when patient therapy is completed.
- A "click" sound indicates a proper connection. To disconnect, press the side of the female connector on the equipment and pull out the air hose.

#### Illustration of ALP® 900 Control Unit + 2 Sleeves

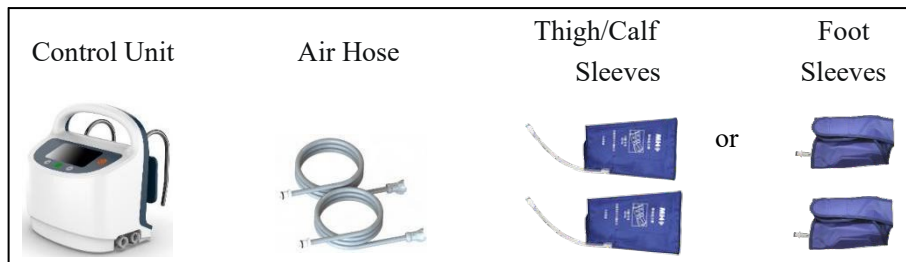

#### Illustration of ALP® 900 Control Unit + 1 Sleeve

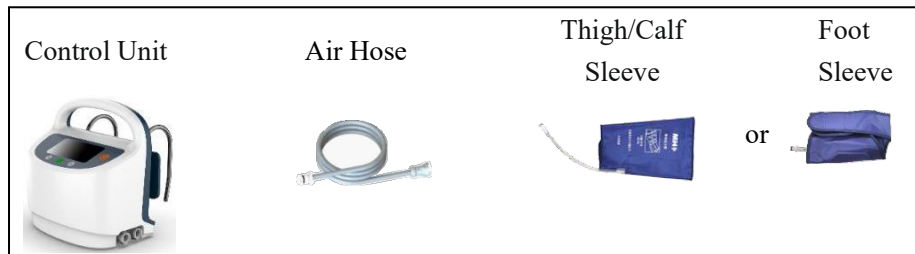

### 6.4 Powering On and Initialization

### 6.4.1 Connect the Power Cord

- Connect the power cord plug of the device to an electrical outlet.
- Long press the "On/Off" button to start the system and enter initialization.

### 6.4.2 Dual Calf or Thigh Sleeves

- If dual calf or thigh sleeves are connected and initialization is completed, the sleeve will not inflate initially. The leg graphic will be displayed with a contour line.
- When inflating, the leg graphic will be highlighted in blue, and the treatment will start. See illustration of LCD screen:

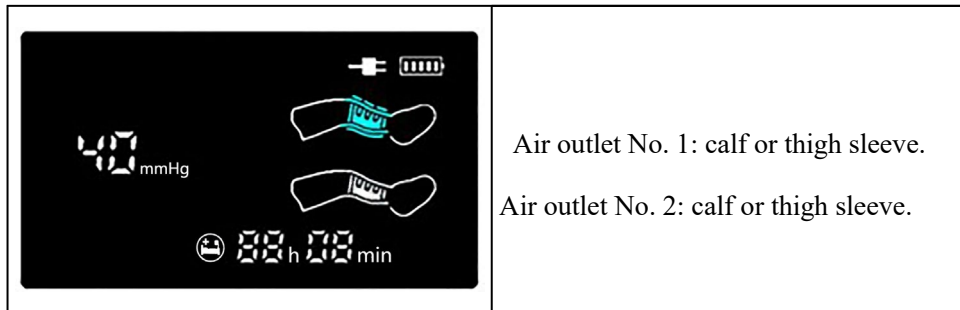

### 6.4.3 Dual Foot Sleeves

- If two foot sleeves are connected, press the "Foot Mode" button for 2 seconds during initialization. A "beep" sound will be heard, and a foot icon along with the words "foot mode" will be displayed at the top of the LCD screen.
- After initialization is completed, the sleeves will not inflate initially. The foot graphic will be displayed with a contour line.
- When inflating, the foot graphic will be highlighted in blue, and the treatment will start. See illustration of LCD screen:

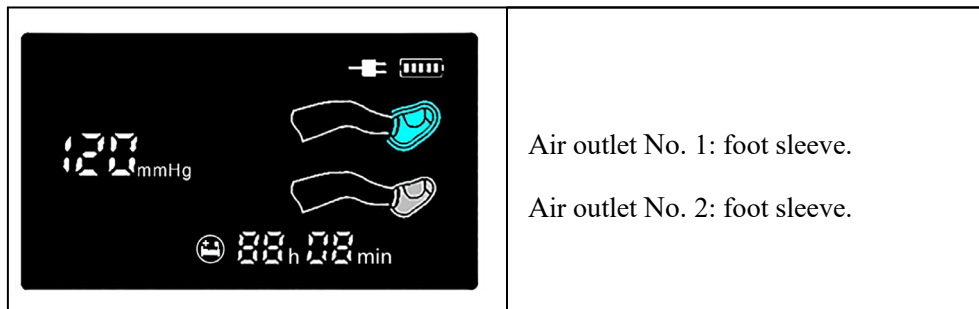

### 6.4.4 Single Calf or Thigh Sleeve

- If one calf or thigh sleeve is connected and initialization is completed, the sleeve will begin to inflate.

- The leg graphic will be highlighted in blue, and treatment will start. See illustration of LCD screen:

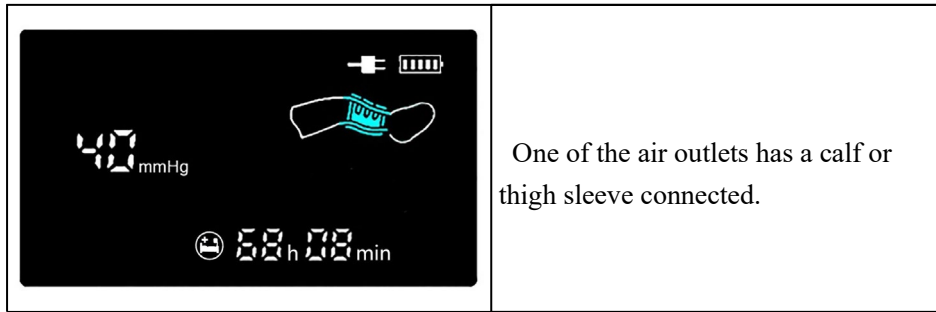

#### 6.4.5 Single Foot Sleeve

- If one foot sleeve is connected, press the "Foot Mode" button for 2 seconds during initialization. A "beep" sound will be heard, and a foot icon along with the words "foot mode" will be displayed at the top of the LCD screen.
- After initialization is completed, the sleeve will begin to inflate.
- The foot graphic will be highlighted in blue, and treatment will start. See illustration of LCD screen:

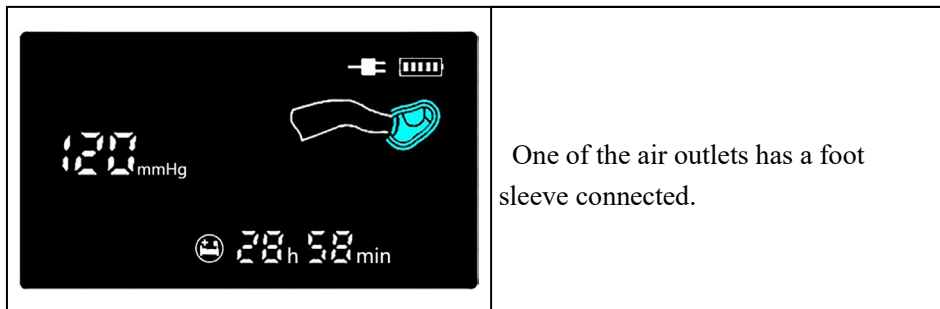



### **6.4.6 Changing Sleeves**

- Do not replace or remove a connected sleeve after the device is turned on. If it is necessary to change the sleeve, first ensure the device is turned off.

## **6.5 Therapy Time Setting**

### **6.5.1 Tracking Therapy Time**

- The default timer mode is to measure Therapy Duration. Upon startup, the timer will automatically start counting the therapy duration.
- If the system is suspended or shut down, the timer will stop. When the system resumes or restarts, the timer will continue from the previous time.

### **6.5.2 Resetting Therapy Time**

- To reset the therapy time, long press the "Time Reset" button for 5 seconds. The system will restart recording the duration of therapy, with the Counting Therapy timer returning to zero or resetting to the set duration for Timed Therapy mode.

### **6.5.3 Timed (Countdown) Therapy Mode**

- After system initialization, long press the "Time Pause" button for 1 second. The Counting Therapy time icon will disappear, and the Timed (Countdown) Therapy icon will illuminate.
- Long press the "Time Reset" button for 3 seconds to switch to Timed Therapy mode.
- To add time to the Timed Therapy countdown time, first press the "Pause" button, then press the "Time Reset" button—each press adds 10 minutes, up to a maximum of 120 minutes.
- After selecting desired therapy time, long press the "Time Reset" button for 3 seconds to confirm the setting. Then press the "Pause" button to start (or resume) the therapy.
- An alarm will sound when the timed period is over, and the system will shut down automatically after 5 minutes.
- Upon restarting, the timer will default to the last set therapy countdown time.

### **6.5.4 Switching Timer Back to Elapsed Therapy Time Mode**

- If the system timer is set to countdown therapy mode, after system initialization, press the "Time Reset" button to enter a paused state. Then press the "Time Reset" button again. The timer countdown icon will disappear, and the elapsed time icon will illuminate and flash.
- Long press the "Time Reset" button for 3 seconds to confirm the switch to elapsed time counting mode. Re-press the "Pause" button to resume therapy, and the system will start counting the cumulative elapsed therapy time.
- If the system is paused or shut down, the timer will stop. After the pause is canceled or the system is restarted, the timer will resume counting from the previous accumulated therapy time. Switching the timer mode clears the accumulated therapy time.

## 6.6 Recommended Visual Inspections

- The correct type of sleeve is connected.
- During inflation, check the LCD display to ensure no fault indications are displayed and that the correct pressure is applied. The preset target inflation pressure is 40mmHg for calf/thigh sleeves and 120mmHg for foot sleeves.
- Ensure no kinks in the tubing, and that connectors are properly locked.
- Avoid placing air hoses or any connections/components under the patient to prevent impacting the effectiveness of the pump or causing skin integrity issues.
- Never move or remove the sleeve while it is inflated, as this may cause damage to the sleeve.
- Use only parts and accessories supplied for use with the ALP® 900 control unit. Using other products with the system is not recommended.

## 6.7 Pause Treatment

- Press the "Pause" button for 1 second to suspend treatment and press it again for 1 second to resume treatment.

## 6.8 Turn Device Off







- Press the "On/Off" button to turn the device on or off.

*Note: To avoid treatment interruption due to AC power failure, ensure that the system is equipped with a fully-charged battery.*

## 6.9 Battery Usage and Displays

- **When the device is plugged in:**

- If the battery is fully charged, the indicator will be static and all five bars will be illuminated on the display.
  - If the battery is not fully charged, the power indicator will roll from battery power null to the current battery power level to indicate charging.
- **When the device is not plugged in:**
    - The indicator is static and shows the approximate battery level.

	Five bars		Four bars
	Three bars		Two bars
	One bar		Zero bar
	AC power supply is connected		

### LCD Display Key for Battery and Power Indicators

**Notes:**

- Initially it takes approximately 25 hours to fully charge the battery.
- When fully charged and in good condition, the system can operate on battery power for about 11 hours.
- When the battery level is at "zero bar" the low battery alarm will trigger, indicating the battery will only last for another 15 minutes. Please connect the AC power source for charging immediately.

*Warning: Do not attempt to force the unit to power on once it has shut down due to low battery power, as this may cause damage to the battery or control unit.*

### 6.9.1 Battery Warnings

- Rechargeable lithium batteries must be used properly.
- Battery replacement by inadequately trained personnel can result in hazards such as overheating, fire, or explosion.



- Do not drop, impact, or immerse the unit in water.
- Avoid contact or ingestion of any leaking electrolyte. If contact occurs, immediately rinse the affected area and seek medical assistance.
- Do not open the battery, dispose of it in a fire, or cause a short circuit as this may result in leakage, explosion, and serious injury.
- Only charge the battery using devices provided by Currie Medical. Improper charging devices may damage the battery or pose a personal threat.
- Store in a cool, dry, and ventilated environment, away from fire and high temperatures. Perform a full charge and discharge every 3 months and replenish the battery to 70%.
- It is strictly forbidden to replace the battery without permission. If replacement is needed, please contact after-sales service.
- Dispose of the battery according to local disposal regulations.

## 6.10 Troubleshooting Guide

- If the fault is caused by user error, check the fault according to the troubleshooting method. If the problem persists, contact the dealer or manufacturer. Internal maintenance of the control unit must be performed by a qualified engineer, and replacement parts must be supplied by Currie Medical. Contact the company's customer service department for technical guidance. During maintenance, please contact our company to obtain the circuit schematic diagram and other relevant information.
- The following tables provide common alarm and sound alarm conditions displayed on the LCD screen, along with descriptions and necessary troubleshooting steps:

Fault Type	Description and Troubleshooting
<p data-bbox="375 638 548 667">Low Pressure</p> 	<ul data-bbox="812 342 1247 1218" style="list-style-type: none"> <li>• After two cycles of inflating (approximately 2 minutes later), the pressure of the thigh or calf sleeve is lower than 35 mmHg; pressure of the foot sleeve is lower than 115 mmHg. The visible warning is activated, and LCD screen displays “air leak” icon and “alarm” icon. The system makes an audible alarm and the blue part flashes when the sleeve is being inflated.</li> <li>• Check sleeves and air hoses for leaks. The visible warning or audible alarm will be cleared if the leak is repaired. If the alarm continues, replace the affected sleeve.</li> <li>• Refer to a service professional if the problem persists.</li> </ul>

Fault Type	Description and Troubleshooting
<p data-bbox="378 562 553 590">High Pressure</p> 	<ul data-bbox="813 352 1242 1094" style="list-style-type: none"> <li>• After two cycles of inflating (approximately 2 minutes later), the pressure of the thigh or calf sleeve is higher than 48 mmHg; pressure of foot sleeve is higher than 130 mmHg. The visible warning is activated, and LCD screen displays “blockage” icon and “alarm” icon. The system makes an audible alarm and the device stops working.</li> <li>• Check sleeves and air hoses for kinks or blockages. Restart the device once the blockage has been cleared.</li> <li>• Refer to a service professional if the problem persists.</li> </ul>

Fault Type	Description and Troubleshooting
<p>System Failure</p> 	<ul style="list-style-type: none"> <li>• If the system detects an internal fault, such as internal connecting tubing loss, control unit not working, the electromagnetic valve not working, or pressure sensor damage, the visible warning will be activated, and the LCD screen displays "Failure" icon and "alarm" icon, and an audible alarm triggers. The system stops working.</li> <li>• Please turn off the device and consult a service professional.</li> </ul>
<p>Low Battery Power</p> 	<ul style="list-style-type: none"> <li>• If the system detects low battery, the visible alarm is activated. LCD screen will display the "Alarm" icon. The system makes an alarm sound and the blank battery level icon "□" flashes on the LCD screen.</li> <li>• Please plug the device to the AC power supply to charge the battery.</li> </ul>

## VII. Cleaning, Service, Maintenance, Storage, and Transportation

### 7.1 Cleaning and Disinfection

- The casing is made from ABS plastic. If soiled, the pump should be cleaned with a little water mixed with neutral or near-neutral pH detergents. Do not use flammable agents or agents that cause decolorization.

*Note: Before cleaning, unplug the power cord from the AC power supply to cut off the system's power.*

#### **Caution:**

- Do not use phenol-based solutions, corrosive compounds, or abrasive pads during disinfection, as they will damage the device casing.
- Avoid immersing electrical components in water during cleaning.
- Do not spray cleaning solution directly on the control unit.
- Do not immerse the tube set in water.

#### **7.1.1 Steps for Point-of-Use Quick-Cleaning:**

1. Rub/scrub the soiled area with a small brush with soft bristles, and use a soft cloth dipped in water with detergents to wipe the soiled area until it is clean.
2. Drop a little water with detergent on dried blood to pre-soak it. After the blood softens, wipe it off using a soft cloth dipped in the detergent solution until no traces of blood are visible.
3. Keep the pump dry.

#### **7.1.2 Steps for Thorough Cleaning:**

1. Rub/scrub all soiled areas with a small brush with soft bristles, and use a soft cloth dipped in water with detergents to wipe the pump until it is clean.
2. Drop a little water with detergent on dried blood to pre-soak it. After the blood softens, wipe it off using a soft cloth dipped in the detergent solution until no traces of blood are visible.
3. Use a soft cloth dipped in a detergent solution to wipe the entire pump.
4. Keep the pump dry.
5. Do not use any abrasive materials to clean the LCD screen of the control unit.
6. After cleaning, conduct a visual inspection to ensure there are no dirt particles on the surface of the equipment.



### 7.1.3 Steps for Low-Level Disinfection:

1. Use a soft cloth dipped in 75% ethyl alcohol to scrub the entire device. Ensure the exposure time is at least 1 minute.
2. Keep the device dry.

## 7.2 Service and Maintenance

- Do not attempt to repair, assemble, or disassemble the device, as this may lead to fire or electric shock.
- Inspect all electrical connections and cables for excessive wear. Check the tube set and connectors for damage.
- If the device is used abnormally (e.g., immersed in water or dropped), contact Currie Medical to arrange for repair or replacement.
- To maintain the product's operating condition, please perform the following maintenance items every 12 months:
  - Check the casing for cracks. If there are visible cracks, contact Currie Medical to arrange for repair.
  - Inspect the power cord sheath for damage. If there is any damage, contact Currie Medical to arrange for repair.

For service or maintenance, please contact:

**Currie Medical Specialties**  
Phone: 800-669-3521  
Email: [cservice@curriemedical.com](mailto:cservice@curriemedical.com)

## 7.3 Storage and Transportation

- Store in a dark, ventilated, dry room, away from liquids, open flames, and sharp objects.
- **Operating temperature:** 5°C to 40°C
- **Transportation and storage temperature:** 5°C to 55°C
- **Operating humidity:** 30% to 80%
- **Transportation and storage humidity:** 30% to 93%
- **Atmospheric Pressure:** 75kPa to 106kPa

## VIII. System Configuration, Serial Number, Country of Origin & Shelf Life

### 8.1 System Configuration List:

Control Unit (ALP® 900)	1 Pcs
Air Hose Set	2 Pcs
Operating Manual (eIFU)	1 Pcs
DVT Garments/Sleeves	1 Pair

### Recommended DVT Compression Sleeves:

Item #	Model	Description
500002	ALP 1	CALF (UP TO 18 INCHES)
500003	ALP 1A	CALF (UP TO 18 INCHES)
500004	ALP 2	CALF (UP TO 24 INCHES)
500006	ALP 3	THIGH (UP TO 29 INCHES)
500008	ALP 4	THIGH (UP TO 36 INCHES)
500010	ALP 2XL	CALF (UP TO 30 INCHES)
500012	PVA/ALP 1	FOOT (UP TO 12EEE)
500013	PVA/ALP 2	FOOT (> THAN 12EEE)
500015	ALP 1SM	CALF (UP TO 14 INCHES)
500016	ALP 2XXL	CALF (UP TO 36 INCHES)













### 8.2 Serial Number & Country of Origin

- Found on the product label located on the back of the ALP® 900.

### 8.3 Shelf Life

- Minimum expected service life of the ALP® 900 is 5 years.

## IX. Symbol Glossary and Explanation

	Caution: Consult accompanying documents		Serial number
	Intended for prescription use only.		Manufacture Date
	Type BF applied part		<b>DISPOSAL: Do not</b> dispose of this product as unsorted household waste. Collection of such waste separately for special treatment is necessary.
	Operators must read this document (operating instructions) before using it. Note: The symbol on the label on the controller is blue.		Indicates that the operating status of the alarm audio is temporarily muted.
	Fragile; handle with care		Keep away from sunlight
	Keep dry		This way up

## X. EMC Appendix

**Notes:** ALP® 900 conforms to IEC60601-1-2 EMC requirements.

It is the responsibility of the user to ensure the electromagnetic compatibility environment of the instrument to function properly. User must install and operate the device based on the provided EMC information.

It is recommended to evaluate the electromagnetic environment before using the instrument to ensure that the surrounding environment will not cause strong electromagnetic interference to the instrument, otherwise it may interfere with the normal operation of the equipment.

Instructions for use: The ME EQUIPMENT or ME SYSTEM is suitable for healthcare environments and so on.

**Warning:** Only the power adapter and battery approved by manufacturer can be used. In order to avoid damage to the instrument, please do not change the charging parts.

Even if other devices meet the emission requirements of the corresponding national standards, the ALP® 900 may still be interfered with by other devices.

**Warning:** In the home environment, this equipment may cause radio interference, so protective measures should be taken. It is forbidden to use the equipment near strong radiation sources (such as unshielded RF source), otherwise it may interfere with the normal operation of the equipment.

**Warning:** Portable or mobile RF communication devices might influence the performances of ALP® 900, please avoid strong electromagnetic disturbance while using, such as close to the mobile phone, microwave oven, etc.

**Warning:** Use of this equipment adjacent to or stacked with other equipment should be avoided because it could result in improper operation. If such use is necessary, this equipment and the other equipment should be observed to verify that they are operating normally.

**Warning:** Portable RF communications equipment (including peripherals such as antenna cables and external antennas) should be used no closer than 30 cm (12 inches) to any part of the ALP® 900, including cables specified by the manufacturer. Otherwise, degradation of the performance of this equipment could result.

**Warning:** Use of accessories, transducers and cables other than those specified or provided by the manufacturer of this equipment could result in increased electromagnetic emissions or decreased electromagnetic immunity of this equipment and result in improper operation.”

**Warning:** Do not approach active high-frequency surgical equipment and magnetic resonance imaging systems in radio frequency shielded rooms, where the intensity of EMI disturbances is high.

**Warning:** Do not near active HF surgical equipment and the RF shielded room of an ME system for magnetic resonance imaging, where the intensity of EM disturbances is high.

**Warning:** Make sure that all electrical accessories connected to the ALP® 900 must comply with IEC 60601-1, if in doubt, consult the technical service department or your local representative.

**Warning:** No unauthorized modification allowed.

Based upon the purpose of its design, this equipment complies with EMC regulations. Including the allowable electromagnetic interference level and necessary electromagnetic shielding performance of the electronic equipment specified by laws and regulations.

The complete elimination of electromagnetic interference is almost impossible unless all equipment that may produce high-frequency signals are excluded. Although some high-frequency equipment itself meets the requirements of EMC regulations, it is impossible to determine whether the radio signal generated by its high-frequency transmitter will affect the normal operation of the equipment when it works with considerable power near the equipment order to ensure the electromagnetic compatibility of the equipment, the equipment needs to be installed, debugged and used according to the attached documents. In case of such a situation, please contact the personnel of the company for a solution.

This equipment generates, uses, and can radiate RF energy and, if not installed and used in accordance with the instructions, may cause harmful interference to radio communications. However, there is no guarantee that interference will not occur in a particular installation. If this equipment does cause harmful interference to radio or television reception, which can be determined by turning the equipment off and on, the user is encouraged to try to correct the interference by one or more of the following measures:

- Operate in strict accordance with the instructions of the ALP® 900 instruction manual to ensure that the device is not subject to electromagnetic interference.
- Keep other devices away from this device to reduce the effects of electromagnetic interference.
- Reorient or relocate the receiving antenna. The effect of electromagnetic interference can be mitigated by adjusting the relative position/mounting angle between the device and other devices.
- Reduce electromagnetic interference by changing the wiring location of other device power/signal cables.
- Reduce electromagnetic interference by changing the power path of other devices.

## Essential Performance

### Description of BASIC SAFETY and ESSENTIAL PERFORMANCE

#### 1. Therapy Pressure :

Leg: 40mmHg (tolerance: -5mmHg to+10mmHg)

Foot: 120mmHg (tolerance: -5mmHg to+10mmHg)

#### 2. Pressure Holding Time: 12s (tolerance: $\pm 1$ s)

#### 3. Intermittent Time: 48s (tolerance: $\pm 2$ s)

#### 4. Total Cycle Time: 60s (tolerance: $\pm 3$ s)

#### 5. Fault Alarm

5.1 Low Pressure Alarm: During normal operation, if the treatment pressure is lower than 35mmHg, the equipment will sound an alarm and display a screen prompt.

5.2 High Pressure Alarm: During normal operation, if the treatment pressure is higher than 50mmHg, the equipment will sound an alarm and display a screen prompt.

5.3 System Failure Alarm: During normal operation, if the system malfunctions, the equipment will sound an alarm and display a screen prompt, and the device stops outputting and releases pressure.

5.4 Low Battery Power Alarm: During normal operation, if the battery level is lower than 13V, the equipment will sound an alarm and display a screen prompt.

#### 6. Working noise: Noise level of the equipment during normal operation shall not exceed 60dB (A).

### Description of how the BASIC SAFETY and ESSENTIAL PERFORMANCE were monitored during each test (Note: For some aspects of basic safety, this monitoring might be carried out before, during and after test)

Testers use visual observation to monitor the specific functions of Currie DVT compression devices before, during and after tests.

#### 1. Treatment Procedures

Treatment pressure: verify according to the experimental method in 2.

Pressure holding time: the duration from the beginning of this inflation and pressurization to the end of this inflation and pressurization.

Intermittent time: the interval between the start of the previous deflation and the start of the next inflation.

Total cycle time: the time from the start of this inflation and compression to the start of the next inflation.

When using a stopwatch to detect and combine with actual operating equipment, it should meet the requirements of Pressure Holding Time, Intermittent Time, and Total Cycle Time.

#### 2. Treatment Pressure

Use a three-way connector to connect the DVT sleeve, pressure gauge, and 1.5-meter air tubing end, and then connect the other end of the 1.5-meter air tubing to the equipment air outlet. And wrapping the DVT sleeve (calf) onto the leg model. Measure the maximum pressure in the calf sleeve in leg mode; measure the maximum pressure of the foot sleeve in foot mode. And using the same method to measure both ports. The measurement results should meet the requirements of Therapy Pressure.

### 3. Fault Alarm

#### 3.1 Low Pressure Alarm

When the device is working normally in leg mode and foot mode, make the tubing falls off or cut the DVT sleeve, the device will sound an alarm, and ALP 900 displays the alarm icon and the low pressure icon "■", without any characters; the blue highlighted part of sleeve graphic on the display screen flashes during inflation. The result should meet the requirements of Low Pressure Alarm.

#### 3.2 High Pressure Alarm

When the device is working normally in leg mode and foot mode, bend the air tubing to completely block it, and the device will sound an alarm. ALP 900 displays the alarm icon and the high-pressure icon "■", without any characters; the device stops outputting and releases pressure, and the blue highlighted part of sleeve graphic on the display screen remains solid. The result should meet the requirements of High Pressure Alarm.

#### 3.3 System Failure Alarm

When the device is working normally in leg mode and foot mode, unplug the solenoid valve connection wire, and the device will sound an alarm. ALP 900 displays the alarm icon and system fault icon "■", without any characters. The result should meet the requirements of System Failure Alarm.

#### 3.4 Low Battery Power Alarm

Use an adjustable DC voltage regulator to supply power, adjust the DC voltage regulator to +16.8V, slowly reduce the output voltage until an alarm sound and display prompt appear: the LCD screen displays the words "Battery low, please charge" and the "alarm" icon (ALP 900 only displays the alarm icon, no characters), and blank battery level icon " " flashes on the display screen., The result should meet the requirements of Low Battery Power Alarm.

### 4. Working Noise

Place the device on a hard countertop, connect the male connector of the 1.5-meter air tubing to the device's air outlet, and then connect the male connector of the DVT sleeve to the female connector of the 1.5-meter air tubing. After the device is in normal working condition after turning on and initialization, use a sound level meter to

measure the A-weighted sound level at 1 meter in front, back, left, right, and top of the device. All should meet the requirements of Working noise.

**Table 1**

<b>Guidance and manufacturer's declaration-electromagnetic emission</b>		
The <b>ALP® 900</b> is intended for use in the electromagnetic environment specified below. The customer or the user of the <b>ALP® 900</b> should assure that it is used in such an environment.		
<b>Emissions Test</b>	<b>Compliance</b>	<b>Electromagnetic Environment-Guidance</b>
Conducted RF emissions CISPR 11	Group 1, Class A	The <b>ALP® 900</b> uses RF energy only for its internal function. Therefore, its RF emissions are very low and are not likely to cause any interference in nearby electronic equipment.
Radiated RF Emissions CISPR 11	Group 1, Class A	The <b>ALP® 900</b> is suitable for use in all establishments, including domestic establishments and those directly networked buildings used for domestic purposes.
Harmonic emissions IEC61000-3-2	N/A	
Voltage fluctuations/flicker emissions IEC61000-3-3	N/A	



**Table 2**

<b>Guidance and manufacturer's declaration-electromagnetic</b>			
The <b>ALP® 900</b> is intended for use in the electromagnetic environment specified below. The customer or the user of the <b>ALP® 900</b> should assure that it is used in such an environment.			
<b>Immunity Test</b>	<b>IEC60601 Test Level</b>	<b>Compliance Level</b>	<b>Electromagnetic Environment -Guidance</b>
Electrostatic discharge (ESD) IEC61000-4-2	±8 kV contact ±2, 4, 8, 15 kV air	±8 kV contact ±2, 4, 8, 15 kV air	Floors should be wood, concrete or ceramic tile. if floors are covered with synthetic material, the relative humidity should be at least 30%
Electrical fast transient/ burst IEC61000-4-4	±2kV for power Supply lines	±2kV for power Supply lines	N/A
Surge IEC 61000-4-5	±1kV line (s) to line(s) ±2kV line (s) to earth(s)	±1kV line (s) to line(s) ±2kV line (s) to earth(s)	N/A
Voltage dips, short interruptions and voltage variations on power supply input lines IEC61000-4-11	Dips: 0% U <sub>T</sub> for 0.5 cycle at 0°, 45°,90°,135°,180°,225°,270 and 315°	Dips: 0% U <sub>T</sub> for 0.5 cycle at 0°, 45°,90°,135°,180°,225°,270 and 315°	N/A
	0% U <sub>T</sub> for 1 cycle at 0°	0% U <sub>T</sub> for 1 cycle at 0°	
	70% U <sub>T</sub> for 25 cycles (50Hz) , 30 cycles (60Hz) at 0°	70% U <sub>T</sub> for 25 cycles (50Hz) , 30 cycles (60Hz) at 0°	
	Interruptions: 0% U <sub>T</sub> for 250 cycles (50Hz) , 300 cycles (60Hz)	Interruptions: 0% U <sub>T</sub> for 250 cycles (50Hz) , 300 cycles (60Hz)	
Power frequency (50Hz/60Hz) magnetic field IEC61000-4-8	30A/m	30A/m	Power frequency magnetic fields should be at levels characteristic of a typical location in a typical commercial or hospital environment.
NOTE: UT is the a.c. mains voltage prior to application of the test level.			

**Table 3**

Guidance and manufacturer's declaration – electromagnetic immunity			
The ALP <sup>®</sup> 900 is intended for use in the electromagnetic environment specified below. The customer or the user of ALP <sup>®</sup> 900 should assure that it is used in such an electromagnetic environment.			
Immunity Test	IEC60601 Test Level	Compliance Level	Electromagnetic Environment -Guidance
Conducted RF IEC61000-4-6	0,15MHz–80MHz 3 V RMS outside the ISM band, <sup>a)</sup> 6 V RMS in the ISM bands	0,15MHz–80MHz 3 V RMS outside the ISM band, <sup>a)</sup> 6 V RMS in the ISM bands	Portable and mobile RF communications equipment should be used no closer to any part of The ALP <sup>®</sup> 900, including cables, than the recommended separation distance calculated from the equation applicable to the frequency of the transmitter. Recommended separation distance $d=1.2 \sqrt{P}$ $d=1.2 \sqrt{P}$ 80MHz to 800MHz d=2.3 800MHz to 2.5GHz Where P is the maximum output power rating of the transmitter in watts (W) according to the transmitter manufacturer and d is the recommended separation distance in meters (m). Field strengths from fixed RF transmitters, as determined by an electromagnetic site survey, <sup>a)</sup> should be less than the compliance level in each frequency range <sup>b)</sup> Interference may occur in the vicinity of equipment marked with the following symbol: 
Radiated RF IEC61000-4-3	3V/m 80 MHz to 2.7 GHz	3V/m 80 MHz to 2.7 GHz	
NOTE 1: At 80 MHz and 800 MHz, the higher frequency range applies. NOTE 2: These guidelines may not apply in all situations. Electromagnetic propagation is affected by absorption and reflection from structures, objects and people.			
a: Field strengths from fixed transmitters, such as base stations for radio (cellular / cordless) telephones and land mobile radios, amateur radio, AM and FM radio broadcast and TV broadcast cannot be predicted theoretically with accuracy. To assess the electromagnetic environment due to fixed RF transmitters, an electromagnetic site survey should be considered. If the measured field strength in the location in which ALP <sup>®</sup> 900 is used exceeds the applicable RF compliance level above, ALP <sup>®</sup> 900 should be observed to verify normal operation. If abnormal performance is observed, additional measures may be necessary, such as re-orienting or relocating The ALP <sup>®</sup> 900. b: Over the frequency range 150 kHz to 80 MHz, field strengths should be less than 3V/m. c: ISM bands between 6.765MHz~6.795 MHz, 13.553 MHz~13.567 MHz, 26.957 MHz~27.283 MHz, 40.66 MHz~40.70 MHz			

**Table 4**

<b>Frequency Range and Level: RF wireless communication equipment</b>
---

<b>Test Frequency (MHz)</b>	<b>Modulation</b>	<b>Minimum immunity Level (V/m)</b>	<b>Immunity Level Applied (V/m)</b>
385	18Hz PM 50%	27	27
450	1 kHz sine FM + 5 Hz deviation	28	28
710 745 780	217Hz PM 50%	9	9
810 870 930	18Hz PM 50%	28	28
1720 1845 1970	217Hz PM 50%	28	28
2450	217Hz PM 50%	28	28
5240 5500 5785	217Hz PM 50%	9	9
<p><b>ATTENTION:</b>  If necessary to achieve the IMMUNITY TEST LEVEL, the distance between the transmitting antenna and the ME EQUIPMENT or ME SYSTEM may be reduced to 1 m. The 1 m test distance is permitted by IEC 61000-4-3.</p>			
<p>a) For some services, only the uplink frequencies are included</p>			

**Table 5**

Recommended separation distances between portable and mobile RF communication the equipment			
<p>The ALP<sup>®</sup> 900 is intended for use in an electromagnetic environment in which radiated RF disturbances are controlled.</p> <p>The customer or the user of ALP<sup>®</sup> 900 can help prevent electromagnetic interference by maintaining a minimum distance between portable and mobile RF communications equipment (transmitters) and the ALP<sup>®</sup> 900 as recommended below, according to the maximum output power of the communications equipment.</p>			
Rated maximum output power of transmitter W(Watts)	Separation distance according to frequency of transmitter M(Meters)		
	150kHz to 80MHz $d=1.2\sqrt{P}$	80MHz to 800MHz $d=1.2\sqrt{P}$	80MHz to 2,5GHz $d=2.3\sqrt{P}$
0,01	N/A	0.12	0.23
0,1	N/A	0.38	0.73
1	N/A	1.2	2.3
10	N/A	3.8	7.3
100	N/A	12	23
<p>For transmitters rated at a maximum output power not listed above, the recommended separation distance in meters (m) can be determined using the equation applicable to the frequency of the transmitter, where P is the maximum output power rating of the transmitter in watts (W) according to the transmitter manufacturer.</p> <p>NOTE 1: At 80 MHz and 800 MHz, the separation distance for the higher frequency range applies.</p> <p>NOTE 2: These guidelines may not apply in all situations. Electromagnetic propagation is affected by absorption and reflection from structures, objects and people.</p>			